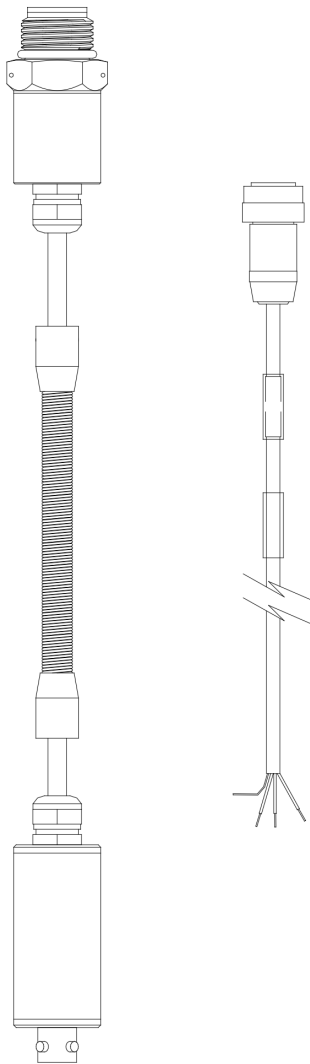


# 165855 Cylinder Pressure Transducer

## Datasheet

Bently Nevada Machinery Condition Monitoring

166815 Rev. L



### Description

The Cylinder Pressure System consists of the 165855 Cylinder Pressure Transducer and the 146824 Interconnect cable. It is intended for measuring the cyclic absolute pressure changes inside a reciprocating compressor cylinder. This transducer is an integral part of a Reciprocating Compressor Condition Monitoring and Asset Management System when utilized with our 3500/77M Cylinder Pressure Monitor and System 1 Plant Asset Management Software.

The Cylinder Pressure Transducer has a robust design for high reliability in harsh chemical environments. The unique, patent-pending design also allows the transducer to continue to provide an accurate pressure reading, even after being continually cycled over large pressure gradients for an extended period of time. The transducer can also withstand over-pressure situations caused by application upsets without diaphragm degradation, returning to normal operation when the operating pressure returns to the transducer's specified operating pressure range. The Cylinder Pressure Transducer is also designed to meet NEMA 4X and IP67 conditions for moisture ingress.

The wetted surface of the transducer is typically installed into an isolation valve or similar pressure indicator port on the compressor. A special adapter is usually required to provide a seal between the pressure indicator port and the transducer (such as the 166393 adapter). The electronics portion of the Cylinder Pressure Transducer is separated from the wetted surface by 1 metre of cable. The electronics must be secured on or near the compressor for optimal performance.



Each pressure sensor will be shipped with pressure-temperature compensation data in order to optimize the measurement. Inputting the supplied data points into the 3500/77 Cylinder Pressure Monitor can minimize the operating temperature effects on the transducer.

	-40 to 185 (electronics housing) °F -40 to 302 (sensor head) °F
Overvoltage Category	II

## Specifications

### Cylinder Pressure Transducer System

Operation outside the specified limits will result in false or inaccurate readings.

#### Transducer Characteristics

Measurement Range	0 to 100/ 250/ 500/ 1000/ 2500/ 5000/ 10,000 psia 0 to 6.8/ 17/ 34.5/ 69/172/ 345/ 689 bar
Proof (Over) Pressure	1.5X Full Scale
Burst Pressure	3X Full Scale (2X FS on 689 bar/ 10,000 psia units)
Full Scale Output	10 ± 0.3 Vdc
Zero	0.5 ± 0.1 Vdc
Power Supply	18 to 30 Vdc
Max. Current	< 15 mA
Compensated Temperature	-40 to 85° C -40 to 185° F
Thermal Zero Shift	-1.0 to +2.0 (for 6.8 and 17 bar/ 100 and 250 psia) %FS  -0.5 to +1.5 (for all other pressure ranges)  Note: Within compensated temperature range.
Thermal Sensitivity Shift	<a href="#">See Graphs and Figures on page 6.</a>
Linearity, Hysteresis, Repeatability	± 0.3 %FS
Frequency response	0Hz to 5500 Hz ± 1 dB
Operating Temperature	-40 to 85 (electronics housing) °C -40 to 150 (sensor head) °C

## Physical & Environmental

Weight	250 g (0.55 lbm) Sensor Head 150 g (0.33 lbm)
Dimensions	See diagram
Materials	Gold plated, per MIL-G-45204 Type III Grade A, C-276 welded to a 316L stainless steel body. (patent pending)
Humidity	95% condensing on exposed surfaces excluding connector
Body	Designed to meet IP67
Operating Temperature	Dependent upon O-ring material Hifluor: -26°C to 150 °C (-15 °F to 302 °F) Ethylene Propylene: -40°C to 150 °C (-40 °F to 302 °F)
Pressure Media	Fluid media compatible with C-276 and either Hifluor or Ethylene Propylene o-ring material (common media below)
Pollution Degree	2
Maximum Use Altitude	2000 meters above sea level

## O-rings



The o-ring utilized must be compatible with the type of gas or fluid that the transducer will be operated in. Consult your local representative for additional assistance.

Hifluor (black)	Hydrogen sulfide, sulfuric acid, butane, fuel oil, petroleum oil, turbine oil, propane, propylene, butylenes, and natural gas.
Ethylene Propylene (purple)	Ammonium hydroxide, anhydrous ammonia
Mounting Torque	68 N-m (50 lbf-ft)

## Accessories

29660-01	Mounting clamp for electronics housing
166393-01	¾-14 NPT Adapter
166393-02	½-14 NPT Adapter
04500022	ADH Dow 4 Elec Ins Comp 4cc Tub
3500/77M	Cylinder Pressure Monitor

## Notes

1. 165855 designed to mate per SAE J1926. Transducer will not seal pressure sufficiently if not mated per SAE J1926.
2. Transducer diaphragm may become damaged upon contact with any foreign object. Care must be taken to protect diaphragm during handling and installation to help ensure proper performance.
3. O-ring must be adequately lubricated with supplied Parker Super-O-Lube prior to installation.
4. Depending upon application, acoustic resonance may occur. For specific details on acoustic resonance and indicator valves, contact your local sales or service representative for more information.
5. If the equipment is used in a manner not specified by the manufacturer, the protection provided by the equipment may be impaired.

It is highly recommended that an isolation valve be used in conjunction with the 165855 Cylinder Pressure Transducer. Valve materials must be compatible with sour gas environments.

For more information about installing and maintaining this product, refer to the Cylinder Pressure Transducer User Guide (document 166820).

## Compliance and Certifications

### FCC

This device complies with part 15 of the FCC Rules. Operation is subject to the following two conditions:

- This device may not cause harmful interference.
- This device must accept any interference received, including interference that may cause undesired operation.

### EMC

EN 61326-1

EMC Directive 2014/30/EU

### RoHS

RoHS Directive 2011/65/EU

### ATEX (where the applicable dash option has been ordered)

EN 60079-0

EN 60079-11

EN 60079-15

ATEX Directive 2014/34/EU

## Hazardous Area Approvals



For the detailed listing of country and product specific approvals, refer to the *Approvals Quick Reference Guide* (108M1756) available from [Bently.com](http://Bently.com).

### ATEX/IECEx

#### 165855



II 1 G Ex ia IIC T4 Ga

II 3 G Ex nA IIC T4 Gc

T4 @ Ta = -40°C to +85°C

## Ordering Information



For the detailed listing of country and product specific approvals, refer to the *Approvals Quick Reference Guide* (108M1756) available from [Bently.com](http://Bently.com).

### 165855 Cylinder Pressure Transducer



All transducers have 7/8-14 UNF thread and are supplied with North American and ATEX approvals.

#### 165855-AA

##### A: Pressure Range Option

<b>01</b>	0 to 6.8 bar (0 to 100 psia)
<b>02</b>	0 to 17 bar (0 to 250 psia)
<b>03</b>	0 to 34.5 bar (0 to 500 psia)
<b>04</b>	0 to 69 bar (0 to 1,000 psia)
<b>05</b>	0 to 172 bar (0 to 2,500 psia)
<b>06</b>	0 to 345 bar (0 to 5,000 psia)
<b>07</b>	0 to 689 bar (0 to 10,000 psia)
<b>11</b>	0 to 6.8 bar (0 to 100 psia) w/ armor
<b>12</b>	0 to 17 bar (0 to 250 psia) w/ armor
<b>13</b>	0 to 34.5 bar (0 to 500 psia) w/ armor
<b>14</b>	0 to 69 bar (0 to 1,000 psia) w/ armor
<b>15</b>	0 to 172 bar (0 to 2,500 psia) w/ armor
<b>16</b>	0 to 345 bar (0 to 5,000 psia) w/ armor
<b>17</b>	0 to 689 bar (0 to 10,000 psia) w/ armor

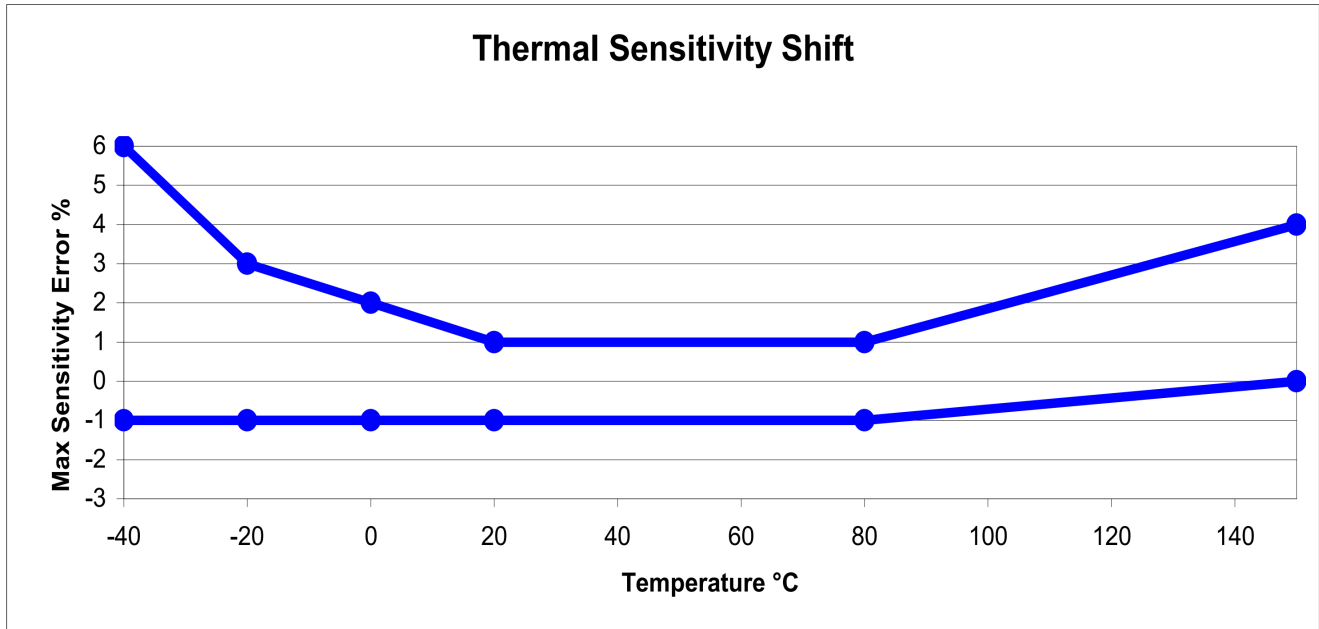
## 146824 Cylinder Pressure Transducer Cable

### 146824-AAAA

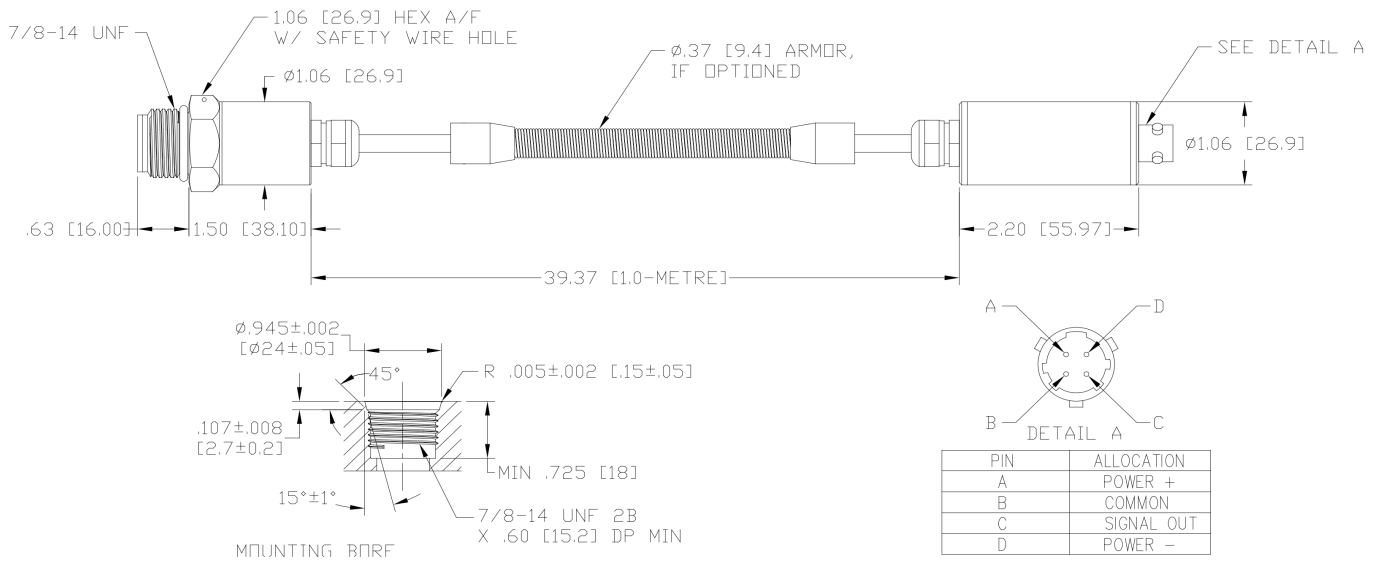
##### A: Length Option

<b>0010</b>	10 ft (3 m)
<b>0025</b>	25 ft (7.6 m)
<b>0050</b>	50 ft (15.2 m)
<b>0100</b>	100 ft (30.5 m)
<b>0200</b>	200 ft (61.0 m)
<b>0300</b>	300 ft (91.4 m)
<b>0400</b>	400 ft (121.9 m)
<b>0500</b>	500 ft (152.4 m)
<b>1000</b>	1,000 ft (304.8 m)

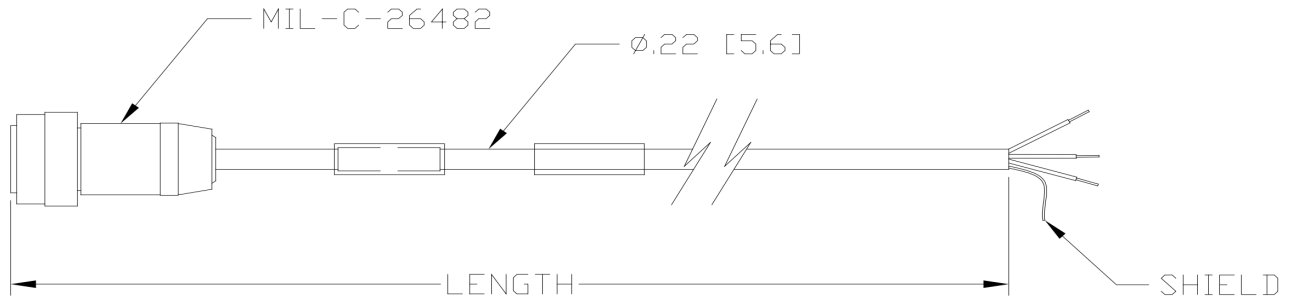
## Graphs and Figures



**Figure 1: Typical Thermal Sensitivity Shift**

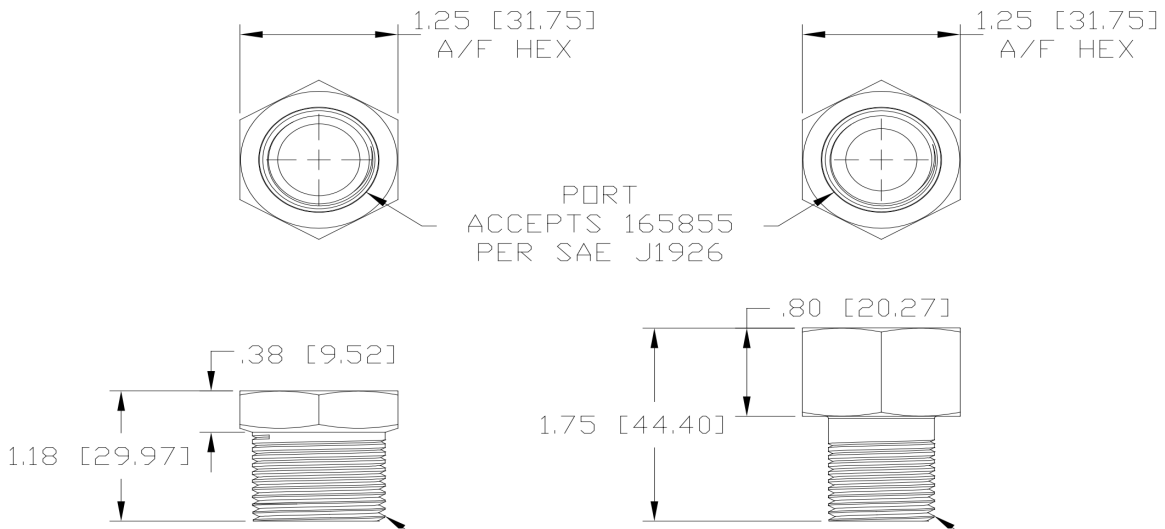


**Figure 2: 165855-AA Cylinder Pressure Transducer and Bore per SAE J1926**



CONNECTOR	WIRE COLOR	WIRE DESCRIPTION
PIN "A"	RED	POWER
PIN "B"	BLACK	COMMON
PIN "C"	WHITE	SIGNAL
PIN "D"	N/C	

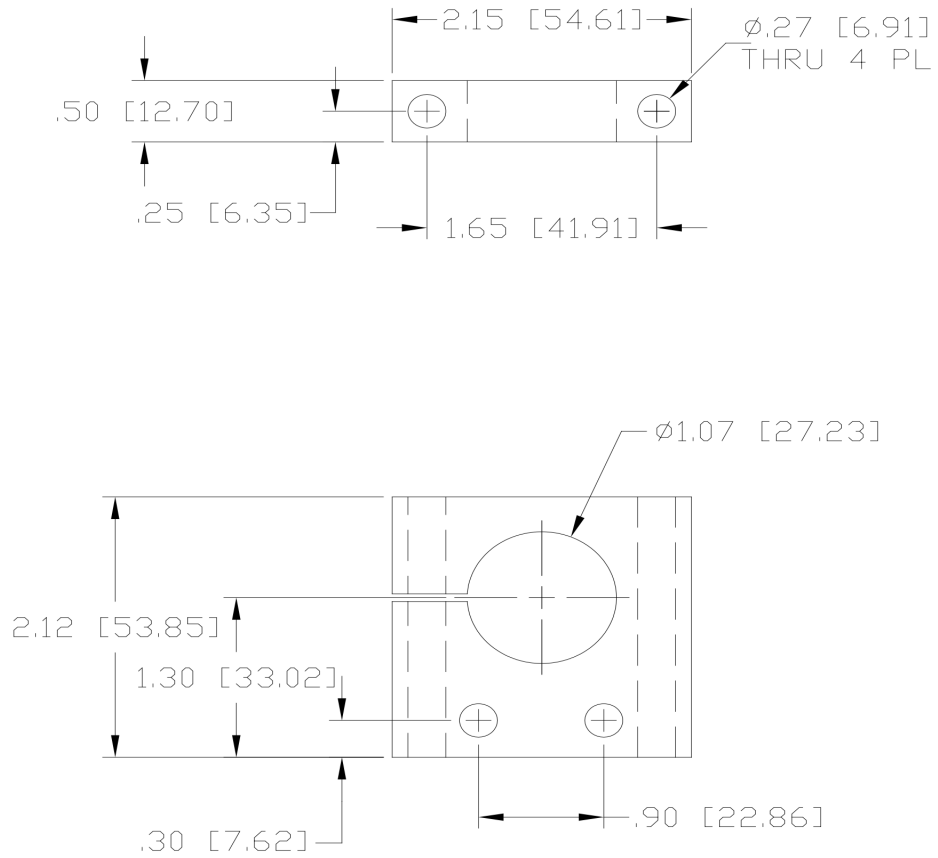
**Figure 3: 146824-AAAA Cylinder Pressure Cable**



**Adapter notes:**

1. The 166393-AA adapter is rated to 345 bar (5,000 psi) per ASME B31.1.
2. When exceeding 345 bar (5,000 psi), the 166393-AA is not recommended. In applications exceeding 345 bar (5,000 psi), direct mounting of the 165855 transducer per SAE J1926 is highly recommended.

**Figure 4: 166393-AA Adapter**



**Figure 5: 29660-01 Mounting Clamp, use with M6 or 1/4-20 (not supplied)**



Copyright 2020 Baker Hughes Company. All rights reserved.



Bently Nevada, Orbit Logo and System 1 are registered trademarks of Bently Nevada, a Baker Hughes Business, in the United States and other countries. The Baker Hughes logo is a trademark of Baker Hughes Company. All other product and company names are trademarks of their respective holders. Use of the trademarks does not imply any affiliation with or endorsement by the respective holders.

Baker Hughes provides this information on an "as is" basis for general information purposes. Baker Hughes does not make any representation as to the accuracy or completeness of the information and makes no warranties of any kind, specific, implied or oral, to the fullest extent permissible by law, including those of merchantability and fitness for a particular purpose or use. Baker Hughes hereby disclaims any and all liability for any direct, indirect, consequential or special damages, claims for lost profits, or third party claims arising from the use of the information, whether a claim is asserted in contract, tort, or otherwise. Baker Hughes reserves the right to make changes in specifications and features shown herein, or discontinue the product described at any time without notice or obligation. Contact your Baker Hughes representative for the most current information.

The information contained in this document is the property of Baker Hughes and its affiliates; and is subject to change without prior notice. It is being supplied as a service to our customers and may not be altered or its content repackaged without the express written consent of Baker Hughes. This product or associated products may be covered by one or more patents. See [Bentley.com/legal](https://www.bentley.com/legal).

1631 Bently Parkway South, Minden, Nevada USA 89423  
Phone: 1.775.782.3611 or 1.800.227.5514 (US only)  
[Bentley.com](https://www.bentley.com)